

REV.	CHANGE	DATE	DESIGNED	APPROVED
G	FRONT PLATE DESING CHANGED, EMC ITEM NO. CAHNGED	13.11. 2024	KOS	MAM

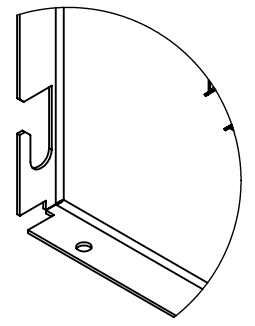

DETAIL A

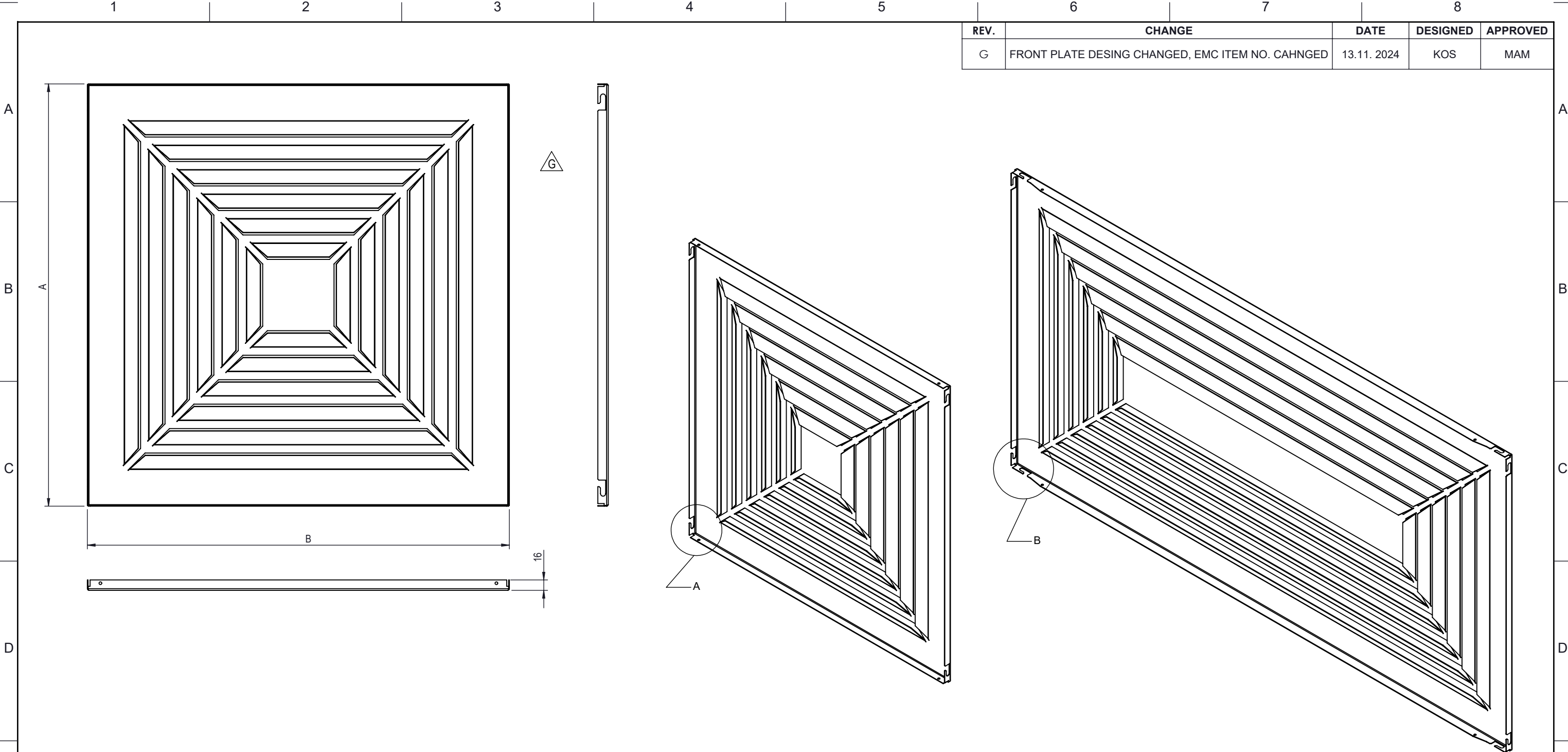
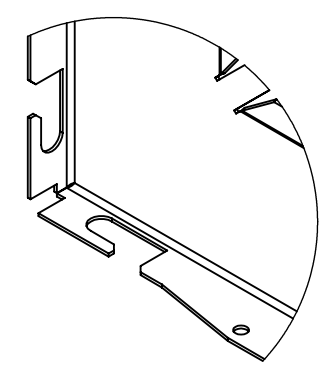

DETAIL B

For magnetic lock system (custom option) magnetic counter plate kit 1073117 to be used.

Size	Camfil Order Ref (EMC Item No.)	Material	Finish	A	B;	Number of vanes	Mass [kg]
3P3	1200091	Carbon Steel	RAL 9010	346	346	2	1,1
3P6	1200092	Carbon Steel	RAL 9010	346	651	2	2
4P4	1200093	Carbon Steel	RAL 9010	498	498	4	2,1
5P5	1200094	Carbon Steel	RAL 9010	549	549	5	2,6
6P6	1200095	Carbon Steel	RAL 9010	651	651	6	3,6
9P6	1200096	Carbon Steel	RAL 9010	651	956	6	5,2
11P5	1200097	Carbon Steel	RAL 9010	549	1149	5	5,3
12P6	1200098	Carbon Steel	RAL 9010	651	1261	6	6,9



DESCRIPTION Front Plate for Cleanseal, Camseal 1, Camseal 2 and Pharmaseal EU 4 WAY			
PROJECT -	LAST REVISION G	WEIGHT See table	
DRAWING REF. Customer Drawing - CL - 4W	SHEET 1/1	SIZE A3	

NB: The copyright of this drawing remains with Camfil. Contents must not be used, copied or disclosed to third parties without prior written consent. All rights reserved.